

Velox™

Magnetic Wireless Cooling Charger Pro Dash & Windshield Mount

User Manual

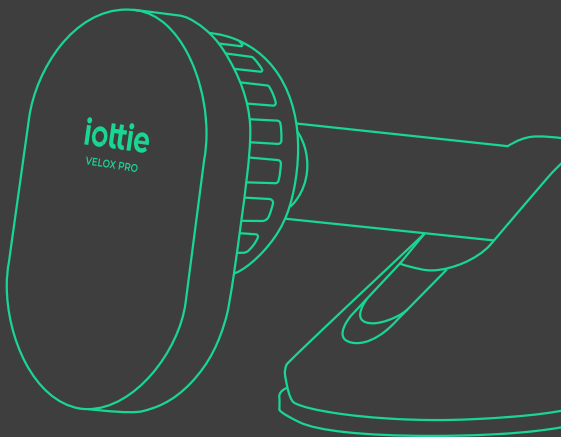



Magnetic Wireless Cooling Charger Pro Dash & Windshield Mount

User Manual

	English	04
	French	16
	Italian	28
	German	40
	Spanish	52

Index

For optimal mounting and charging, please follow the detailed instructions within this manual when using the Velox Pro Dash & Windshield Mount. iOttie is not liable for possible damages due to product misuse.

01 Product Information

At a Glance

Device Compatibility

Product Specifications

Power Adapter Specifications

02 Installation

Attaching the Mount

Connecting to Power

Adjusting the Mount

Mounting Your iPhone

Using the CryoFlow Technology

01 Product Information

At a Glance

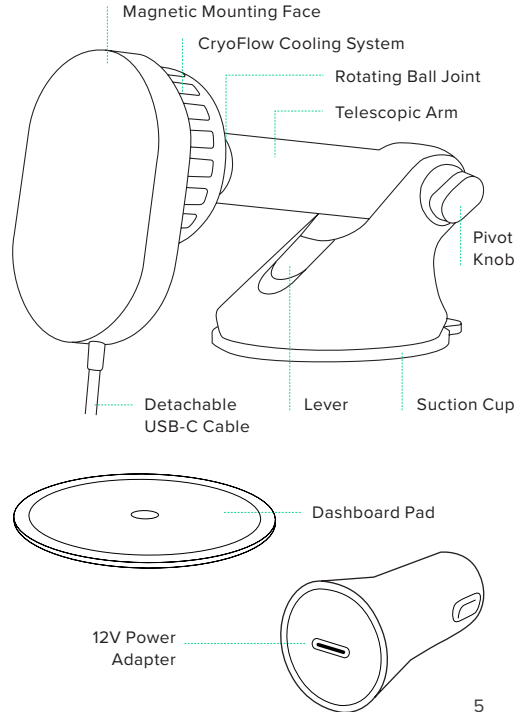

CryoFlow Cooling System

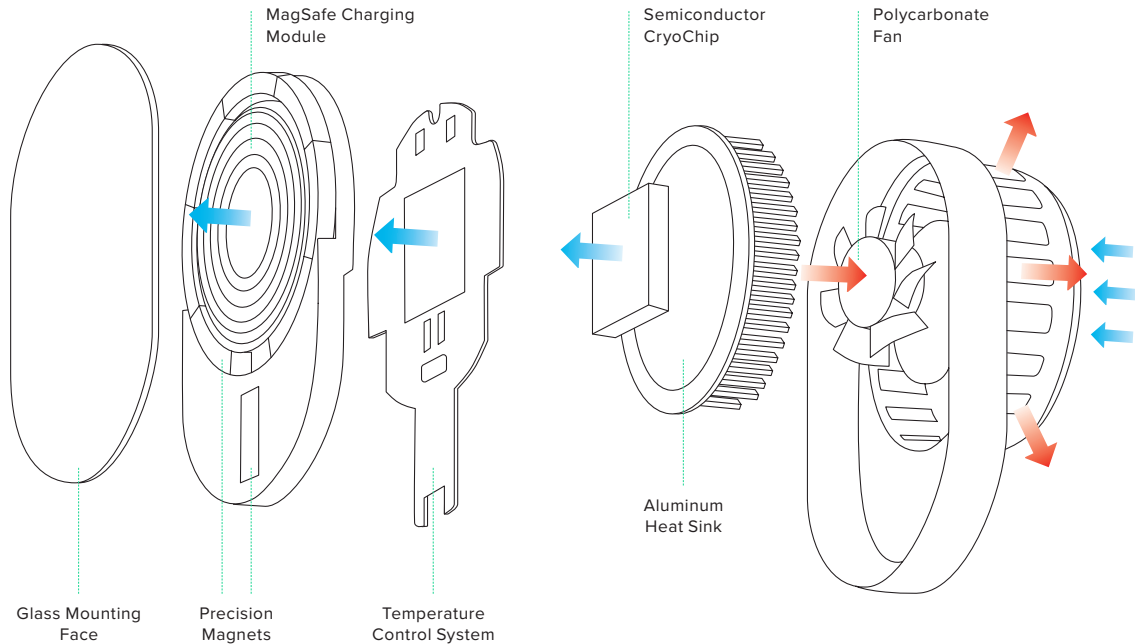

Device Compatibility

Velox products are designed for use with MagSafe compatible iPhones and MagSafe compatible cases. Compatible devices include the iPhone series 12 and later.

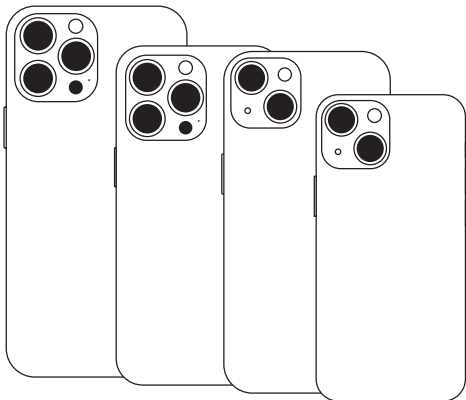

Product Specifications

Item	Specification
Total Input	DC 5V-3A DC 9V-2A
Wireless Charger Output	7.5 W
Cable Length	5 ft
Mount Length	5 in
Width	2.55 in
Height	3.25 in
Weight	7.03 oz

Power Adapter Specifications

Input	Output
DC 5V-3A DC 9V-2A DC 12V-1.5A	7.5 W

02 Installation

Attaching the Dash Mount

Choose an installation method: dashboard/flat surface (A) or windshield (B).

Option A

Dashboard or Flat Surface Installation

Choose a flat area on the vehicle's dashboard and wipe any dust or debris from the surface.

**If your vehicle has a leather dashboard we recommend windshield mounting to avoid damaging your dash.*

1. Peel off the film on the dashboard pad and evenly press onto the desired installation location. Wait at least 20 minutes before attaching the mount.

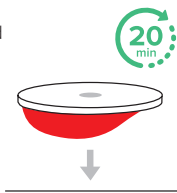

**The longer you wait before attaching the mount, the more secure the hold will be.*

2. Remove the plastic cover from the suction cup and firmly press the mount onto the dashboard pad.
3. Push down the locking lever to engage suction.



The dashboard pad is mounted with a semi-permanent adhesive tape. Once removed, it cannot be re-mounted.

When mounting, it is recommended that the surface and product be above 65°F.

When removing the dashboard pad, please use caution. We recommend removing slowly from the edge to avoid damage.

Option B

Windshield Installation

Choose a location on the windshield and wipe any dust or debris from the surface.

*The dashboard pad should not be used for windshield mounting.

1. Peel off the protective film on the suction cup and press firmly onto the windshield.
2. Push down the locking lever to engage suction.

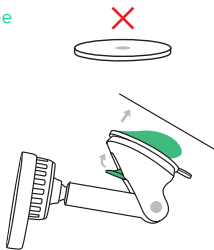

To reuse the suction cup, simply rinse under warm water and let air dry to restore tacky suction.

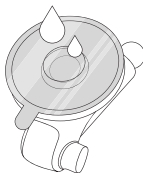

Connecting to Power

Attach the USB-C cable to the Velox Pro. Then, connect the cable to your vehicle's USB-C port or auxiliary power outlet via the included 18W adapter.

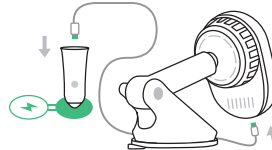

*The Velox Pro does not have an on/off switch. Once the cable is plugged in and the vehicle is turned on, the mount will stay on.

Adjusting the Mount

The Velox Pro will arrive in the closed position. To extend the telescopic arm, simply pull it outwards. When adjusting the arm for the first time, you may need to use extra force to loosen the internal lubricant.

The telescopic arm extends from 4–7" and pivots on a 260° arc. To raise and lower the arm, loosen the pivot knob. After adjusting, tighten the knob to secure the arm. You can also adjust the angle of the mounting face by tilting or rotating it.

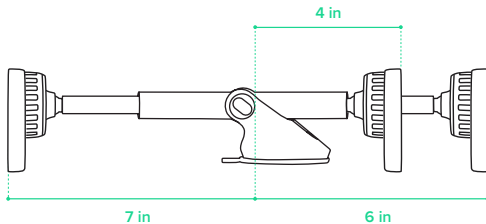

Mounting Your Phone

Peel off the protective film on the magnetic mounting face. Then simply tap your phone against the mount and the magnets will hold it in place. Charging will begin automatically.

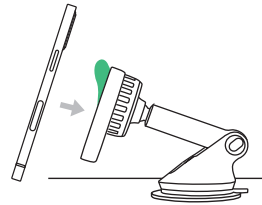

Using the CryoFlow Technology

Once your phone is attached to the Velox Pro Mount, the CryoFlow technology will automatically turn on and begin cooling. You are now ready to start driving.

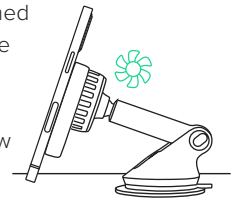

Indice

Pour un montage optimal, veuillez suivre les instructions détaillées de ce manuel lorsque vous utilisez l'Velox Pro. iOttie n'est pas responsable des dommages éventuels causés par une mauvaise utilisation du produit.

01 Informations du produit

Aperçu

Compatibilité de l'appareil

Caractéristiques du produit

Caractéristiques du adaptateur d'alimentation

02 Installation

Fixation du support

Connexion à l'alimentation

Ajustement de l'assemblage

Installation de votre téléphone

Utilisation de la technologie CryoFlow

01 Informations du produit

Aperçu

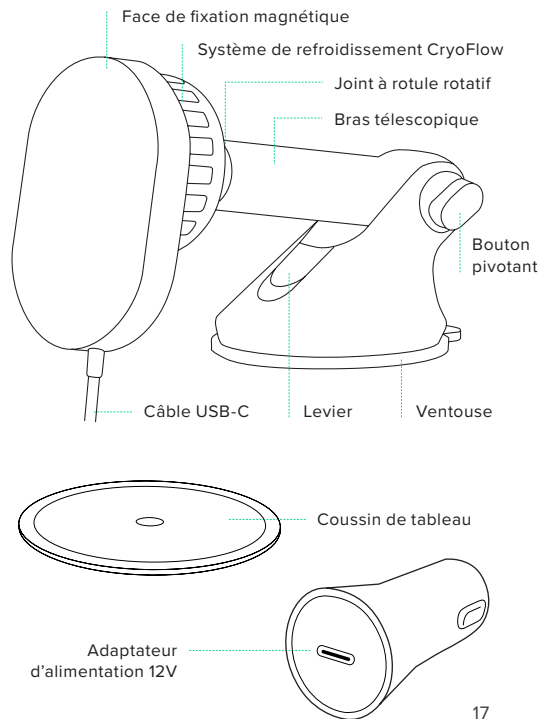

Système de refroidissement CryoFlow

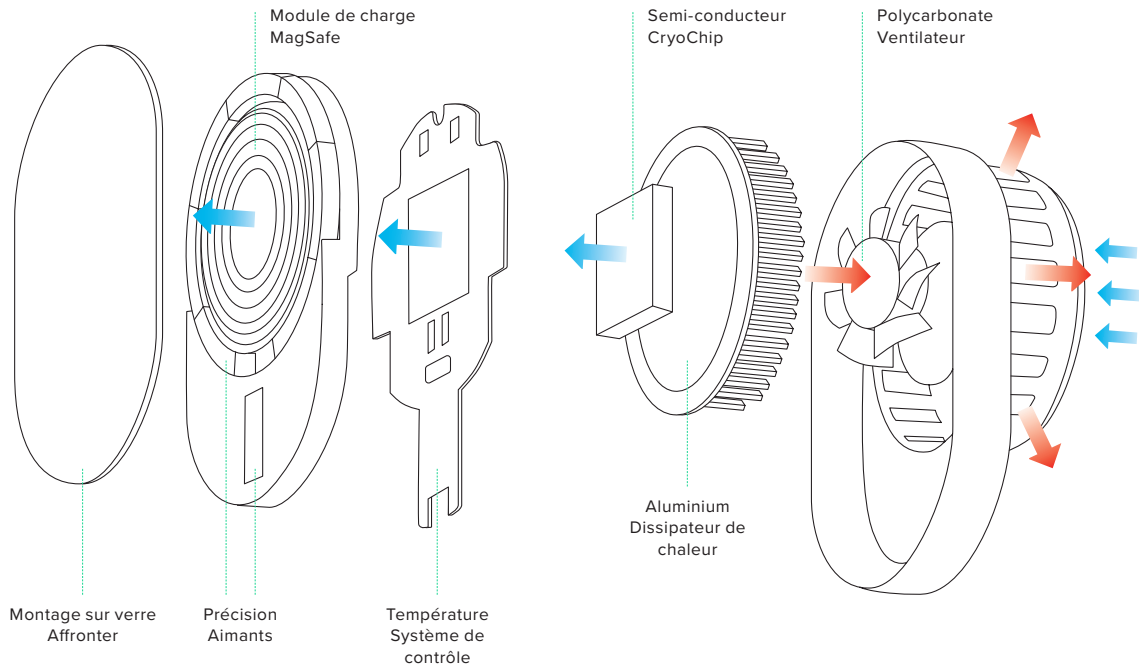

Compatibilité

Ces produits Velox est uniquement compatible avec les iPhones et les étuis de la série MagSafe. Les iPhones compatibles MagSafe comprennent la série iPhone 12 et versions ultérieures.

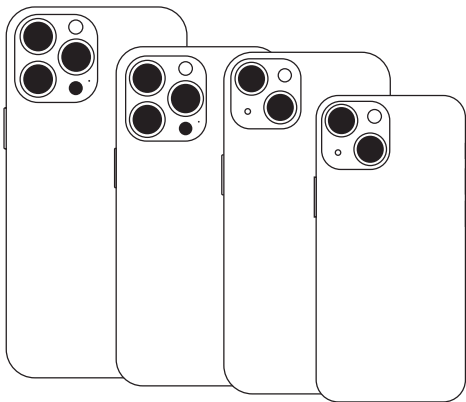

Caractéristiques du produit

Article	Caractéristique
Entrée totale	DC 5V-3A DC 9V-2A
Sortie du chargeur sans fil	7.5 W
Longueur du câble	1.5 m
Longueur du support	12.7 cm
Largeur	6.48 cm
Hauteur	8.26 cm
Poids	199.28 g

Caractéristiques du adaptateur d'alimentation

Entrée	Sortie
DC 5V-3A DC 9V-2A DC 12V-1.5A	7.5 W

02 Installation

Fixation du support

Choisissez une méthode d'installation : tableau de bord/surface plane (A) ou pare-brise (B).

Option A

Installation sur tableau de bord ou surface plane

Choisissez une surface plane sur le tableau de bord du véhicule et essuyez toute poussière ou débris de la surface.

***Si votre véhicule est équipé d'un tableau de bord en cuir, nous vous recommandons une fixation au pare-brise pour éviter d'endommager votre tableau de bord.**

1. Retirez le film du tableau de bord puis collez-le sur le lieu d'installation désiré. Attendez 20 minutes pour que l'adhésif adhère avant de ne pas passer à l'étape suivante.



2. Retirez le film protecteur de la ventouse puis appuyez-la fermement sur la surface plane du tableau de bord.
3. Enclenchez le levier de verrouillage vers le bas pour mettre en œuvre la succion.



Le coussin du tableau de bord est fixé d'un ruban adhésif semi-permanent. Une fois retiré, il ne peut pas être remonté.

Lors du montage, il est recommandé que la surface et le produit soient au-dessus de 18°C.

Lors du retrait du coussin du tableau de bord, veuillez faire preuve de prudence. Nous vous recommandons de retirer lentement du bord pour éviter tout dommage.

Option B

Installation au pare-brise

Choisissez un emplacement sur le pare-brise et essuyez toute poussière ou débris de la surface.

*Le coussin de tableau de bord n'est pas recommandé pour le montage sur pare-brise.

1. Décollez le film protecteur de la ventouse et appuyez fermement sur le pare-brise.
2. Abaissez le levier de verrouillage pour activer la ventouse.

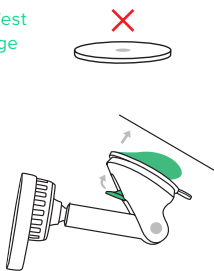

Pour réutiliser la ventouse, il suffit de la rincer à l'eau tiède et de la laisser sécher à l'air libre pour rétablir l'aspiration collante.

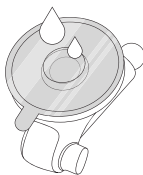

Connexion à l'alimentation

Connectez le câble USB-C fourni à l'adaptateur 12V inclus et branchez l'adaptateur dans la prise de courant auxiliaire de votre véhicule.

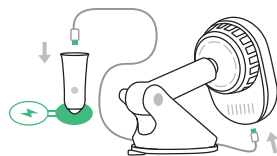

*Le support de tableau de bord Velox n'a pas l'interrupteur marche/arrêt. Une fois le câble branché et le véhicule allumé, le support restera allumé.

Ajustement de l'assemblage

Le Velox Pro arrivera en position fermée. Pour étendre le bras télescopique, il suffit de le tirer vers l'extérieur. Lorsque vous ajoutez le bras pour la première fois, vous devrez peut-être utiliser une force supplémentaire pour desserrer le lubrifiant interne.

Le bras télescopique s'étend de 10 cm à 18 cm et pivote sur un arc de 260°. Pour lever et baisser le bras, desserrez le boulon de pivot. Après le réglage, serrer le bouton pour fixer le bras. Vous pouvez également régler l'angle de la face de montage en l'inclinant et en la faisant pivoter.

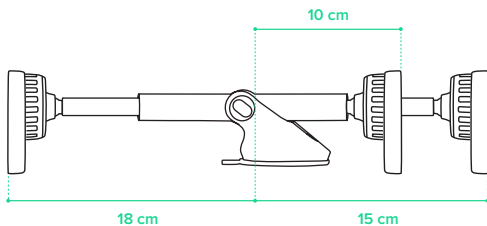

Installation de votre téléphone

Tapez simplement votre téléphone contre le support et les aimants le maintiendront en place. La charge commencera automatiquement.

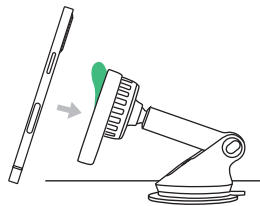

Utilisation de la technologie CryoFlow

Une fois votre téléphone connecté au Velox Pro, la technologie de CryoFlow s'allume automatiquement et commence à refroidir. Vous êtes maintenant prêt(e) à conduire.

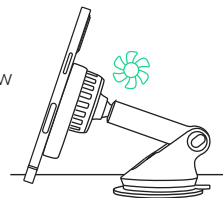

Indice

Per un montaggio ottimale, si prega di seguire le istruzioni dettagliate all'interno di questo manuale quando si usa il Velox Pro. iOttie non è responsabile per eventuali danni causati da un uso improprio del prodotto.

01 Informazioni del prodotto

Sommario

Compatibilità del dispositivo

Specifiche del prodotto

Specifiche dell'adattatore

02 Installation

Collegare il supporto

Collegamento di energia

Regolazione del supporto

Montatura del all'alimentazione

Utilizzo della tecnologia CryoFlow

01 Informazioni del prodotto

Sommario

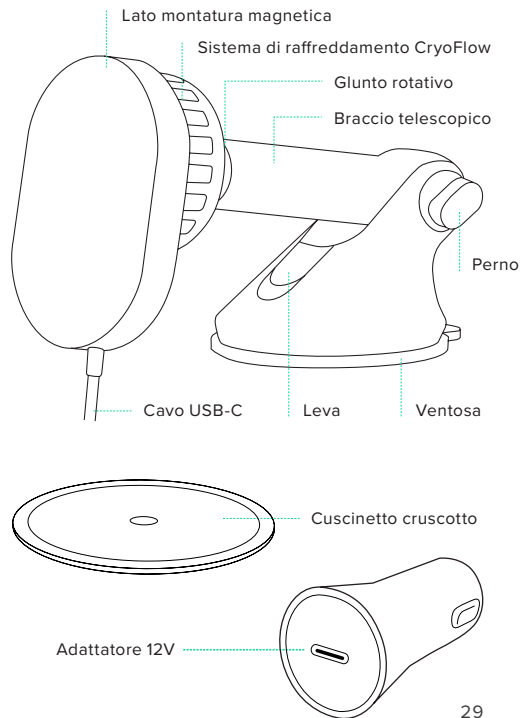

Sistema di raffreddamento CryoFlow

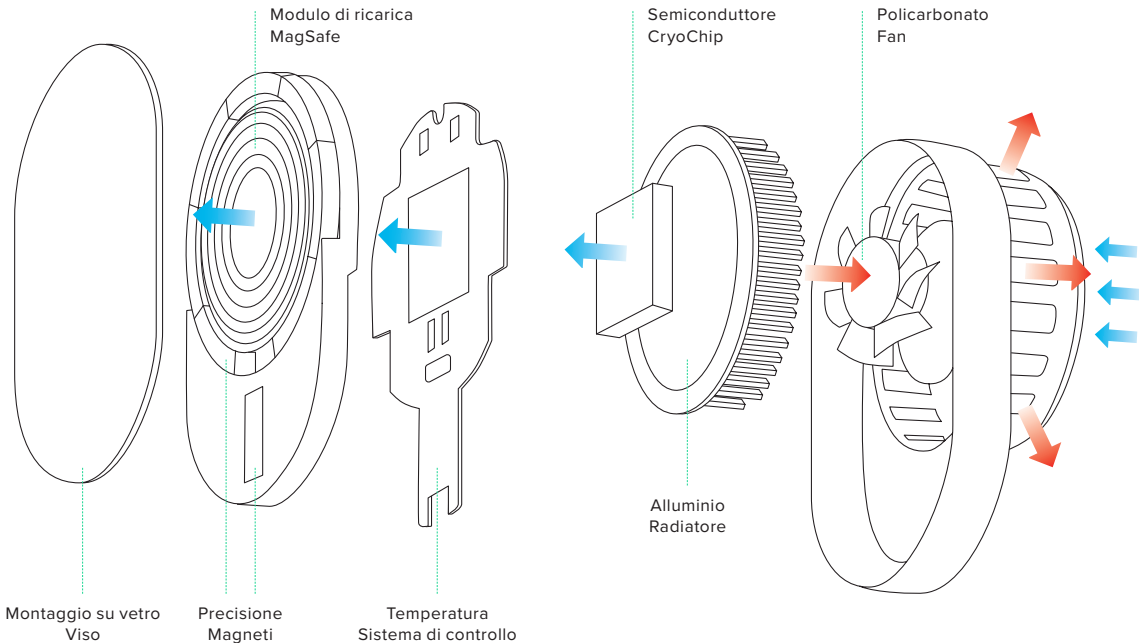

Compatibilità del dispositivo

I prodotti Velox sono compatibili solo con iPhone e le custodie della serie MagSafe. Gli iPhone compatibili con MagSafe includono la serie iPhone 12 e successive.

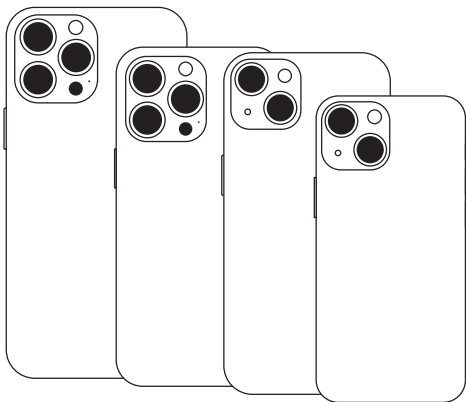

Specifiche del prodotto

Descrizione	Specifiche
Ingresso totale	DC 5V-3A DC 9V-2A
Uscita di ricarica wireless	7.5 W
Lunghezza Cavo	1.5 m
Lunghezza Montatura	12.7 cm
Larghezza	6.48 cm
Altezza	8.26 cm
Peso	199.28 g

Specifiche dell'adattatore

Ingresso	Produzione
DC 5V-3A DC 9V-2A DC 12V-1.5A	7.5 W

02 Installazione

Collegare il supporto

Scegliere un metodo di installazione: cruscotto/
superficie piatta (A) o parabrezza (B).

Opzione A

Installazione sul cruscotto o superficie piatta

Scegliere un'area piatta del cruscotto del
veicolo e pulire polvere o detriti dalla superficie.

***Se il vostro veicolo ha un cruscotto in pelle,
raccomandiamo l'installazione sul parabrezza per
evitare danni.**

1. Staccare il film sul cruscotto
e attaccarlo sul luogo di
installazione desiderata.
Aspettare 20 minuti perché
l'adesivo sia ben fissato
prima di procedere al passo
successivo.



2. Staccare la pellicola protettiva
sulla ventosa e premere
saldamente il supporto sul
cruscotto.
3. Premere la leva di bloccaggio
verso il basso per attivare
l'aspirazione.



Il cuscinetto del cruscotto è montato con
adesivo semi-permanente. Una volta rimosso,
non si può rimontare.

Alla montatura, si consiglia di controllare che la
superficie ed il prodotto siano sopra i 18°C.

Si prega di fare attenzione quando si rimuove
il cuscinetto del cruscotto. Si consiglia di
rimuovere lentamente partendo dall'estremità
per evitare danni.

Opzione B

Installazione sul parabrezza

Scegliere un'area del parabrezza e pulire polvere o detriti dalla superficie.

***Il cuscinetto del cruscotto non è raccomandato per montatura sul parabrezza.**

1. Rimuovi la pellicola protettiva della ventosa, e premere fermamente sul parabrezza.
2. Abbassare la leva di sicurezza per assicurare la ventosa.

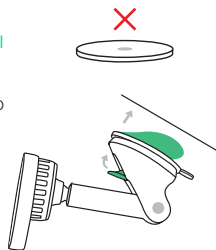

Per riusare la ventosa, sciacquare sotto acqua tiepida e lasciare asciugare all'aria.



Collegamento di energia

Connettere il cavo USB-C all'adattatore incluso a 12V, e inserire l'adattatore alla presa ausiliaria della vostra macchina.

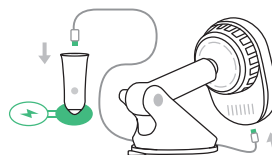

***La Montatura Cruscotto Velox non ha accensione/ spegnimento. Una volta che il cavo è collegato e il veicolo in moto, la montatura rimarrà fissata.**

Regolazione del supporto

Il Velox Pro arriverà in posizione chiusa. Per estendere il braccio telescopico è sufficiente tirarlo verso l'esterno. Quando si regola il braccio per la prima volta, potrebbe essere necessario esercitare una forza maggiore per allentare il lubrificante interno.

Il braccio telescopico si estende da 10-18 cm e ruota su un arco di 260°. Per alzare e abbassare il braccio, allentare la manopola del perno. Dopo la regolazione, serrare la manopola per fissare il braccio. È inoltre possibile regolare l'angolazione della superficie di montaggio inclinando o ruotando.

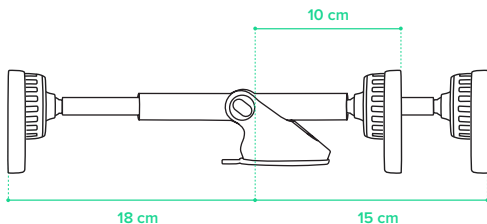

Montatura del all'alimentazione

Poggiare il vostro telefono contro la montatura e i magneti la manterranno assicurata. La ricarica partirà automaticamente.

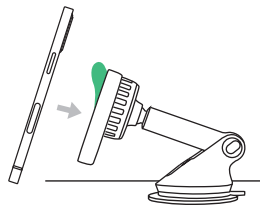

Utilizzo della tecnologia CryoFlow

Una volta collegato il telefono al Velox Pro, la tecnologia di CryoFlow si accenderà automaticamente e inizierà a raffreddarsi. Siete ora pronti per la guida.

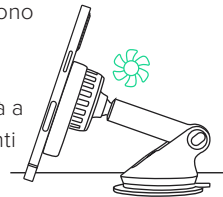

Index

Befolgen Sie für einen optimalen Einbau die detaillierten Anweisungen in diesem Handbuch, wenn Sie das Velox Pro verwenden. iOttie haftet nicht für mögliche Schäden, die auf Grund einer unsachgemäßen Verwendung des Produkts entstehen.

01 Produktinformationen

Auf einen Blick

Kompatibilität der Geräte

Produktspezifikationen

Spezifikationen des Netzteils

02 Installation

Befestigung der Halterung

Anschließen der Stromversorgung

Einstellung der Halterung

Befestigung Ihres Telefons

Mit der CryoFlow-Technologie

01 Produktinformationen

Auf einen Blick

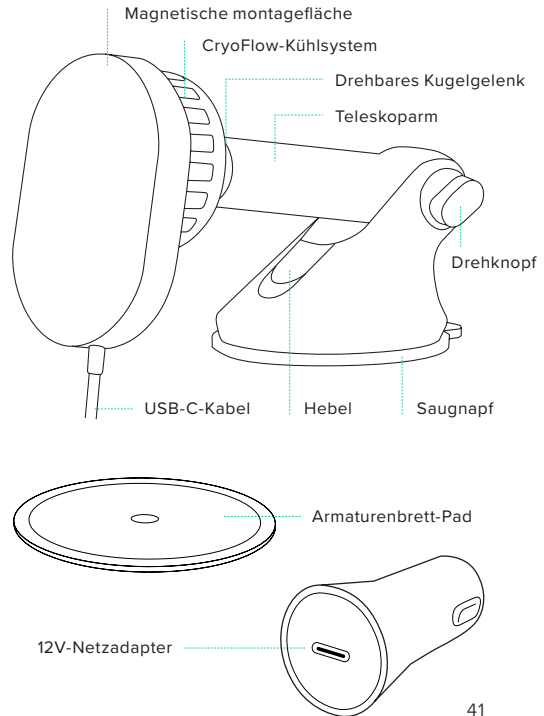

CryoFlow-Kühlsystem

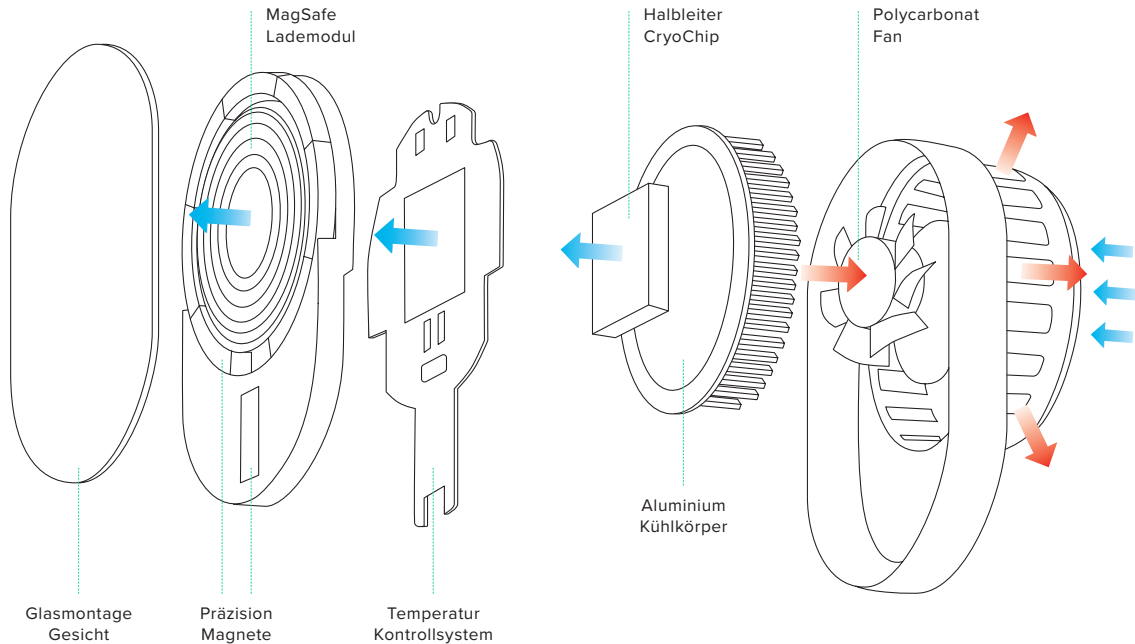

Kompatibilität der Geräte

Dieses Produkt ist ausschließlich mit iPhones und Hüllen der MagSafe-Serie kompatibel. Zu den mit MagSafe kompatiblen iPhones gehören die iPhone 12-Serie und höher.

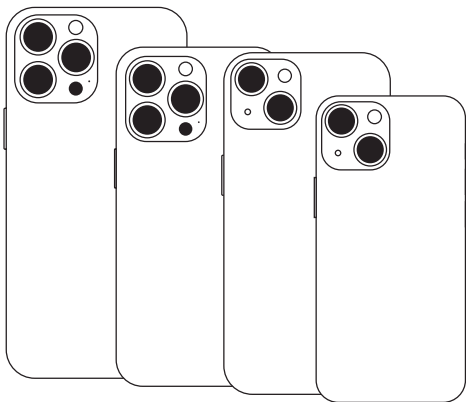

Produktspezifikationen

Daten	Spezifikation
Gesamteingang	DC 5V-3A DC 9V-2A
Ausgabe für kabelloses Aufladen	7.5 W
Kabellänge	1.5 m
Länge der Befestigung	12.7 cm
Breite	6.48 cm
Höhe	8.26 cm
Gewicht	199.28 g

Spezifikationen des Netzteils

Eingabe	Ausgabe
DC 5V-3A DC 9V-2A DC 12V-1.5A	7.5 W

02 Installation

Befestigung der Halterung

Wählen Sie eine Installationsmethode:

Armaturenbrett/glatte Oberfläche (A) oder
Windschutzscheibe (B).

Möglichkeit A

Installation auf dem Armaturenbrett oder einer
flachen Oberfläche

Wählen Sie eine flache Stelle auf dem
Armaturenbrett des Fahrzeugs und entfernen
Sie Staub und Schmutz von der Oberfläche.

***Wenn Ihr Fahrzeug ein ledernes Armaturenbrett hat,
empfehlen wir die Montage an der Windschutzscheibe,
um eine Beschädigung des Armaturenbretts zu
vermeiden.**

1. Ziehen Sie den Film vom
Armaturenbrett-Pad ab und
kleben Sie den gewünschten
Installationsort fest. Warten
Sie 20 Minuten.



2. Ziehen Sie den Schutzfilm
vom Saugnapf ab und drücken
Sie die Halterung fest auf das
Armaturenbrett-Pad.



3. Drücken Sie den
Verriegelungshebel nach
unten, um die Absaugung
zu aktivieren.

Das Armaturenbrett-Pad wird mit einem
semipermanenten Klebeband befestigt.
Einmal entfernt, kann es nicht wieder
angebracht werden.

Bei der Montage wird empfohlen, dass die
Oberfläche und das Produkt eine Temperatur
von über 18°C haben.

Gehen Sie beim Entfernen des Armaturenbrett-
Pads bitte vorsichtig vor. Wir empfehlen, das
Pad langsam von der Ecke aus zu entfernen,
um Schäden zu vermeiden.

Möglichkeit B

Einbau an der Windschutzscheibe

Wählen Sie eine Stelle auf der Windschutzscheibe und entfernen Sie Staub und Schmutz von der Oberfläche.

*Das Armaturenbrett-Pad wird nicht für die Montage an der Windschutzscheibe empfohlen.

1. Ziehen Sie die Schutzfolie vom Saugnapf ab und drücken Sie ihn fest auf die Windschutzscheibe.
2. Drücken Sie den Verriegelungshebel nach unten, um die Ansaugung zu aktivieren.

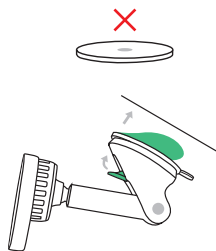

Um den Saugnapf wiederzuverwenden, spülen Sie ihn einfach unter warmem Wasser ab und lassen Sie ihn an der Luft trocknen, damit er wieder haftet.



Anschließen der Stromversorgung

Schließen Sie das beiliegende USB-C-Kabel an den mitgelieferten 12-V-Adapter an und stecken Sie den Adapter in die Hilfssteckdose Ihres Fahrzeugs.

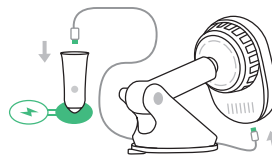

*Der Velox-Armaturenbrettbefestigung hat keinen Ein/Aus-Schalter. Sobald das Kabel eingesteckt ist und das Fahrzeug eingeschaltet wird, ist die Halterung eingeschaltet.

Einstellung der Halterung

Der Velox Pro kommt in der verriegelten Position an. Um den Teleskoparm ausfahren, ziehen Sie ihn einfach nach außen. Wenn Sie den Arm zum ersten Mal einstellen, müssen Sie möglicherweise zusätzliche Kraft aufwenden, um das interne Schmiermittel zu lösen.

Der Teleskoparm erstreckt sich von 10-18 cm und schwenkt auf einem 260°-Bogen. Lösen Sie zum Heben und Senken des Arms den Drehknopf. Ziehen Sie nach dem Einstellenden Drehknopf fest, um den Arm zu sichern. Sie können auch den Winkel der Montagefläche anpassen, indem Sie sie neigen oder drehen.

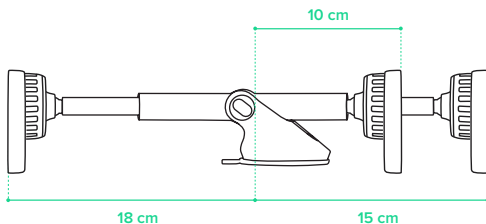

Befestigung Ihres Telefons

Halten Sie Ihr Handy einfach an die Halterung, und die Magnete halten es an Ort und Stelle. Der Ladevorgang wird automatisch gestartet.

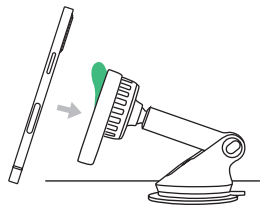

Mit der CryoFlow-Technologie

Sobald Ihr Telefon an Velox Pro angeschlossen ist, schaltet sich die CryoFlow-Kühltechnologie automatisch ein und beginnt mit der Kühlung. Schon können Sie losfahren.

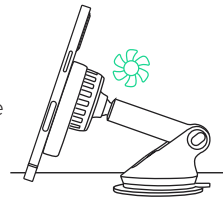

Índice

Para lograr un rendimiento óptimo, siga atentamente las instrucciones que se incluyen en este manual al usar el Velox Pro. iOttie no es responsable por posibles daños debidos al uso incorrecto del producto.

01 Información del producto

A simple vista

Compatibilidad de dispositivos

Especificaciones del producto

Especificaciones del adaptador de corriente

02 Instalación

Colocación del soporte

Conexión a la corriente

Ajuste del soporte

Montar su teléfono

Uso de la tecnología CryoFlow

01 Información del producto

A simple vista

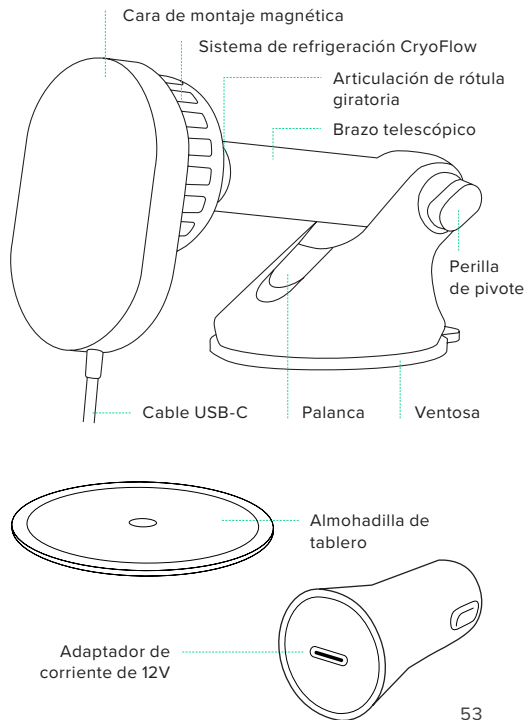

Sistema de refrigeración CryoFlow

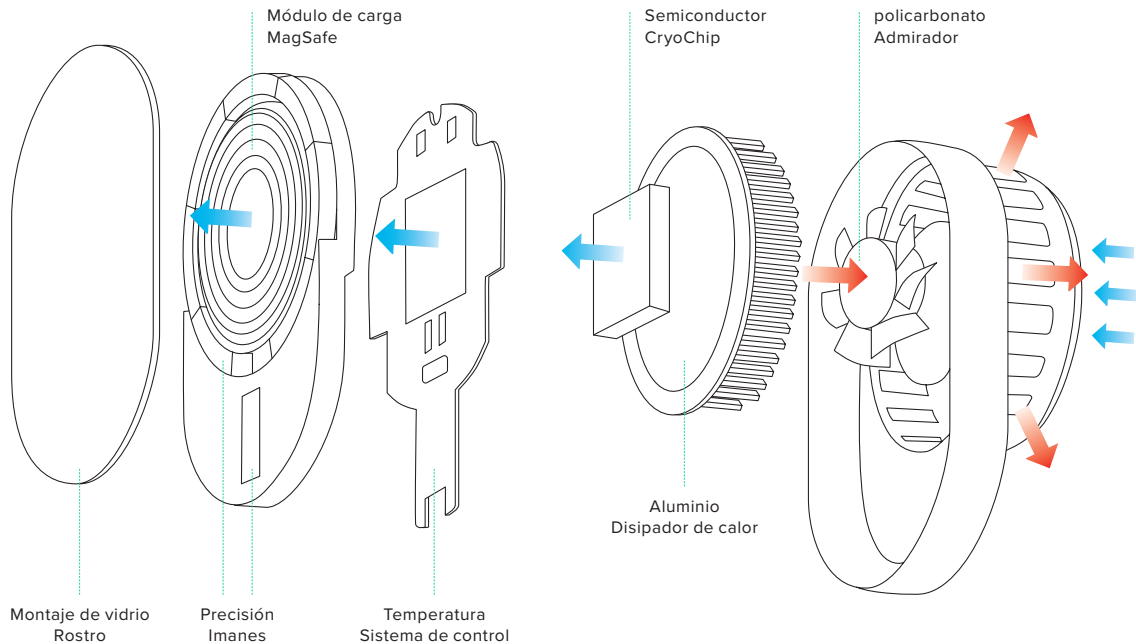

Compatibilidad de dispositivos

Los productos Velox solo son compatible con iPhones y fundas de la serie MagSafe.

Los iPhones compatibles con MagSafe incluyen la serie iPhone 12 y posteriores.

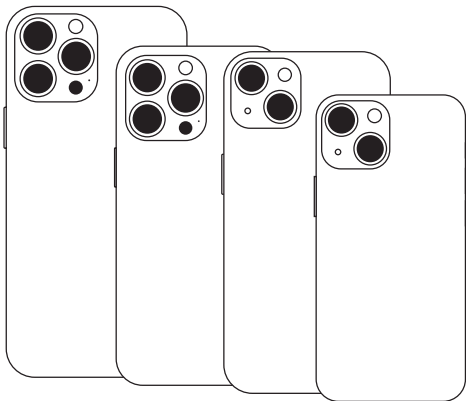

Especificaciones del producto

Elemento	Especificación
Entrada Total	DC 5V-3A DC 9V-2A
Salida del cargador sin cables	7.5 W
Longitud del cable	1.5 m
Longitud de la montura	12.7 cm
Ancho	6.48 cm
Altura	8.26 cm
Peso	199.28 g

Especificaciones del adaptador de corriente

Entrada	Salida
DC 5V-3A DC 9V-2A DC 12V-1.5A	7.5 W

02 Instalación

Instalando el soporte

Elija un locación de instalación: tablero/
superficie plana (A) o parabrisas (B).

Opción A

Instalación en el tablero o en una superficie plana

Elija una superficie plana en el tablero del
vehículo y limpie el polvo o residuos que pueda
haber en ella.

*Si su vehículo tiene un tablero de cuero, recomendamos
el montaje en el parabrisas para evitar dañar al tablero.

1. Quite el papel protector de
la almohadilla del tablero y
péguela en el lugar que desee.
Espere entre 20 minutos antes
de proceder al siguiente paso.



2. Quite el papel protector
de la ventosa y presione
firmemente el soporte sobre
la almohadilla del tablero.
3. Presione hacia abajo la
palanca de bloqueo para
activar la succión.



La almohadilla del tablero está montada con
una cinta adhesiva semipermanente. Una vez
que es retirada, no puede montarse otra vez.

Al hacer el montaje, se recomienda que
la superficie y el producto tengan una
temperatura superior a los 18°C.

Tenga cuidado al retirar la almohadilla del
tablero. Recomendamos retirarla lentamente
desde el borde para evitar dañarla.

Opción B

Instalación en el parabrisas

Elija una ubicación en el parabrisas y limpie el polvo o residuos que puedan haber en su superficie.

*La almohadilla del tablero no se recomienda para el montaje en el parabrisas.

1. Retire la película protector de ventosa y presiónela firmemente en el parabrisas.
2. Presione la palanca de bloqueo para activar la succión.

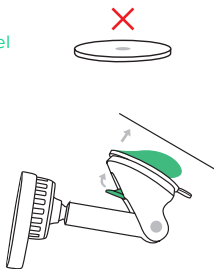

Para volver a usar la ventosa, simplemente enjuáguela con agua tibia y deje que se seque al aire para que recupere su succión pegajosa.

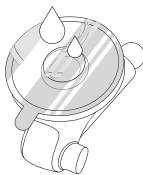

Conexión a la corriente

Conecte el cable USB-C incorporado al adaptador de 12V incluido y enchufe el adaptador a la toma eléctrica auxiliar de su vehículo.

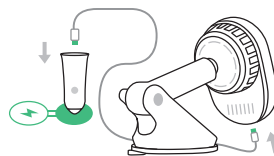

*El soporte para tableros de Velox no tiene un interruptor de encendido/apagado. Una vez que el cable esté enchufado y el se encienda el vehículo, la montura se mantendrá activada.

Ajuste del soporte

El Velox Pro llegará en la posición cerrada. Para extender el brazo telescópico, simplemente tire de él hacia afuera. Al ajustar el brazo por primera vez, es posible que deba aplicar una fuerza adicional para aflojar el lubricante interno.

El brazo telescópico se extiende de 10 a 18 cm y gira en un arco de 260°. Para subir y bajar el brazo, afloje la perilla de pivote. Después de ajustar, apriete la perilla para asegurar el brazo. También puede ajustar el ángulo de la cara de montaje inclinándose o girándola.

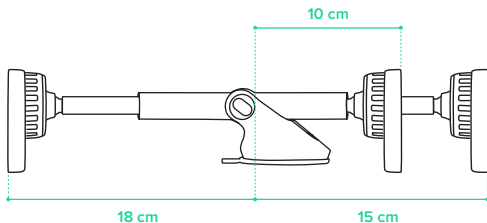

Montar su teléfono

Simplemente toque la montura con su teléfono y los imanes lo mantendrán en su sitio. La carga comenzará de forma automática.

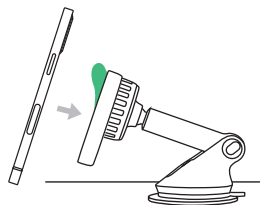

Uso de la tecnología CryoFlow

Una vez que su teléfono esté conectado al Velox Pro, la tecnología CryoFlow se encenderá automáticamente y comenzará a enfriarse. Ya está listo para empezar a manejar.

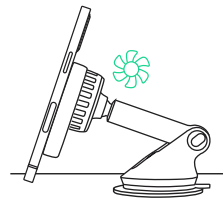

Operation Warnings

This equipment has been tested and found to comply with the limits for a Class B digital device, pursuant to part 15 of the FCC Rules. These limits are designed to provide reasonable protection against harmful interference in a residential installation. This equipment generates uses and can radiate radio frequency energy and, if not installed and used in accordance with the instructions, may cause harmful interference to radio communications. However, there is no guarantee that interference will not occur in a particular installation. If this equipment does cause harmful interference to radio or television reception, which can be determined by turning the equipment off and on, the user is encouraged to try to correct the interference by one or more of the following measures:

- Reorient or relocate the receiving antenna.
- Increase the separation between the equipment and receiver.
- Connect the equipment into an outlet on a circuit different from that to which the receiver is connected.
- Consult the dealer or an experienced radio/TV technician for help

Changes or modifications not expressly approved by the party responsible for compliance could void the user's authority to operate the equipment.

This device complies with Part 15 of the FCC Rules. Operation is subject to the following two conditions:

(1) this device may not cause harmful interference, and (2) this device must accept any interference received, including interference that may cause undesired operation.

RF Exposure Warning Statements

This equipment complies with FCC radiation exposure limits set forth for an uncontrolled environment. This equipment shall be installed and operated with minimum distance 20cm between the radiator & body.

This device contains licence-exempt transmitter(s)/receiver(s) that comply with Innovation, Science and Economic Development Canada's licence-exempt RSS(s). Operation is subject to the following two conditions:

- (1) This device may not cause interference.
- (2) This device must accept any interference, including interference that may cause undesired operation of the device.

L'émetteur/récepteur exempt de licence contenu dans le présent appareil est conforme aux CNR d'Innovation, Sciences et Développement économique Canada applicables aux appareils radio exempts de licence. L'exploitation est autorisée aux deux conditions suivantes :

- (1) L'appareil ne doit pas produire de brouillage;
- (2) L'appareil doit accepter tout brouillage radioélectrique subi, même si le brouillage est susceptible d'en compromettre le fonctionnement.

Radio Frequency Exposure Statement for IC

This equipment complies with IC exposure limits set forth for an uncontrolled environment. This equipment shall be installed and operated with minimum distance 20cm between the radiator & body.

Cet équipement est conforme aux limites d'exposition IC définies pour un environnement non contrôlé. Cet équipement doit être installé et utilisé avec une distance minimale de 20cm entre le radiateur et la carrosserie.

Important Safety Information

This manual contains important safety and operating instructions for the Velox™ Pro Magnetic Wireless Charging Dash & Windshield Mount (VLXWCG204).

Please read all instructions and safety information before using this product. If damage occurs as a result of failure to follow the instructions, the warranty will be voided.

- Do not expose to rain, moisture, or snow.
- Using an attachment made or sold by anyone other than the manufacturer is not recommended, doing so may result in an increased risk of fire, electric shock, or injury.
- Do not operate this magnetic wireless charging mount if it has received a sharp blow, been dropped, or otherwise damaged in any way; take it to a qualified service person.
- Do not disassemble this magnetic wireless charging mount; take it to a qualified service person when service or repair is required. Incorrect reassembly may result in electric shock or fire.
- To reduce the risk of electric shock, unplug this car charger before attempting any maintenance or cleaning. Turning off the vehicle controls will not reduce this risk.
- Avoid extended exposure to direct sunlight, which may damage the device.
- Exposing this product to open flames may cause it to explode.
- Do not expose this product to strong magnetic fields.
- Use a dry, soft lint-free cloth to clean. Do not use any corrosive cleaner or oil to clean.

*Always obey traffic laws and pay attention to the road. Do not attempt to use this device while driving.

This product complies with the radio interference requirements of the European Community.



This product is designed and manufactured with high quality materials and components, which can be recycled and reused.



The product must not be discarded as household waste, and should be delivered to an appropriate collection facility for recycling. Proper disposal and recycling helps protect natural resources, human health and the environment. For more information on disposal and recycling of this product, contact your local municipality, disposal service, or the shop you bought this product.



Designed in New York City. 470 7th Ave, New York, NY 10018.
Made in China. U.S. Patent Pending ©2023 iOttie. All rights reserved. iOttie and Velox are registered trademarks owned by iOttie, Inc. John 3:16

Apple, the Apple logo, iPhone, iPod, iPod touch, Mac, macOS, Magsafe and Siri are trademarks of Apple Inc., registered in the U.S. and other countries.



The Velox Pro Magnetic Wireless Charging Dashboard & Windshield Mount is backed by a 2 year warranty.

iottie

MagSafe Compatible

Only compatible with MagSafe iPhone series and cases.