

Aivo Boost™

Dual Port Car Charger
with Alexa Built-in

User Manual

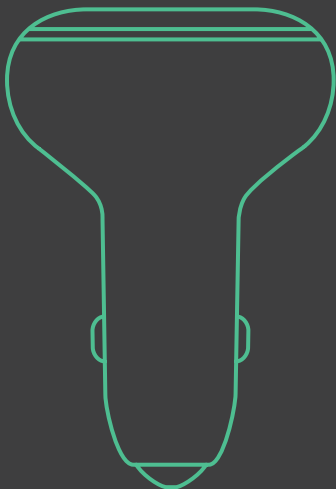

Aivo Boost™

Dual Port Car Charger
with Alexa Built-in

User Manual

	English	04
	French	16
	Italian	26
	German	36
	Spanish	46
	Japanese	56

Index

For an optimal user experience, please follow the detailed instructions in this manual.

01 Getting Started

- User Requirements
- Product Specifications
- Button Controls
- LED Indicators

02 Product Setup

- Power On
- Setup Mode
- Add Device
- Alexa is Ready

03 Using Alexa

- Welcome to Alexa
- How to Wake Alexa
- Alexa Settings & Preferences
- Tips & Things to Try

04 Charging Your Devices

- Charging Ports

01 Getting Started

Welcome to the Aivo Boost! This manual will walk you through detailed product information, device installation and operation, using Alexa, and so much more!

User Requirements



Download the iOttie Connect App from the Apple App Store or the Google Play Store on your smartphone.



Download the Amazon Alexa App from the Apple App Store or the Google Play Store on your smartphone.



*Make sure you have a reliable cellular data connection and power source in order to use Alexa.



Product Specifications

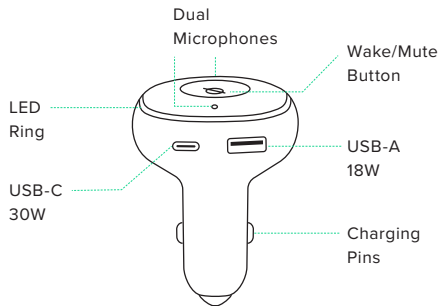

Item	Specification
Total Input	12–24V
USB-C Output	Up to 30W 5V/3A, 9V/2A, 12V/1.5A - PD3.0/QC4.0+
USB-A Output	Up to 18W 3.6-6.5V/3A, 6.5-9V/2A, 9-12V/1.5A - QC3.0
Total Output	48W
Depth	2.93"
Width	2"
Height	2"
Weight	1.6oz

Button Controls

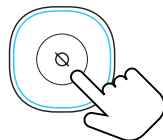



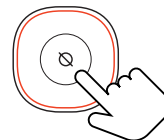





Press: Wake Alexa



Press & Hold (3 sec):
Mute/Unmute

LED Indicators

-  Powering On
-  Searching for Bluetooth Connection
-  Device Not Found
-  Device Connected
-  Wake Word Activated
-  Thinking
-  Device Not Connected
-  Muted
-  No Interaction in Progress

02 Product Setup

Power On

Plug the Aivo Boost into your vehicle's 12V power socket, then start the engine.

Setup Mode

Setup Mode will begin automatically.

The LED ring will flash orange as you are redirected to the Alexa App to add a new device.

Add Device

In the Alexa App, navigate to **Add Device > Auto Accessory**, then **select iOttie Aivo Boost (####)** from available devices, and pair device. Allow location access and make sure Bluetooth is discoverable and turned on.

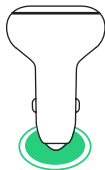

Alexa is Ready

Once device is paired and connected, the LED ring will flash blue three times before turning off. Alexa is now ready to use.

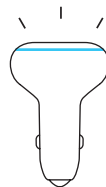

*Device will now connect automatically when it is powered on and your smartphone is in close range.

*To unpair device, hold the wake/mute button for 5 seconds until it flashes orange and select "Forget Device" from phone's Bluetooth settings.



Updating Device Firmware via iOttie Connect App

For an optimal user experience, make sure you have the most up-to-date device firmware installed from the iOttie Connect App. Follow instructions for updating device firmware in the app.

03 Using Alexa

Welcome to Alexa

With Alexa, you can ask for directions, play music, place calls, listen to audiobooks, check the weather, control your smart home devices, and so much more—all while keeping your hands on the wheel and your eyes on the road.

For an optimal experience, please follow the detailed instructions for Alexa setup found in the manual or the iOttie Connect App.

- Some Alexa skills may require an Amazon Prime membership.
- Make sure your phone's Bluetooth is on and connected to your car's Bluetooth.
- The Aivo Boost with Built-in Alexa uses your cellular data when not connected to Wi-Fi. A clear network connection is required for Alexa to work properly, otherwise there may be delays or interruptions. iOttie is not liable for data usage.
- Alexa streams from the cloud. Please note that this may use data. Data charges may apply.

- Alexa streams media instead of local files. Please note that this may use data. iOttie is not liable for data usage.
- For voice messaging, please allow permission settings by going to Contacts > Profile and Settings > Permission.

How to Wake Alexa



OR



A **Wake Word** can be used to ask Alexa anything. The wake word is simply "Alexa."

Tap on the **Wake Button** instead of using the wake word.

- ! There will be no visual cue on your smartphone that announces the connection except that the color of Aivo Boost's LED light should be blue.
- ! The Alexa App must be running in the background of your phone for the device to work. Your phone will automatically launch the Alexa App in the background upon connection.

Alexa Settings & Preferences

[Navigation Settings]

Alexa will use your default maps app. To use a specific map (i.e. Waze or Google Maps) the default must be changed within the Alexa App.

1. Go to the menu and select “Settings”
2. Select “Commute”
3. Select “Default Navigation App”

[Music Settings]

When playing music, Alexa will default to Amazon Music. If using another service, the default must be changed within the Alexa App.

1. Go to the menu and select “Settings”
2. Select “Music & Podcasts”
3. Select “Default Services”

[Call and Text Message Settings]

For voice messaging and calling, please allow permission settings by going to:

Contacts > Profile and Settings > Permission.

*Alexa App menu names subject to change at any time.

Things to Try with Alexa

With Alexa, users can ask for directions, play music, make hands-free calls, control smart home devices, and much more. Just ask!



Navigation

Alexa, navigate to Prospect Park.
Alexa, find me the nearest gas station.
Alexa, get directions to home.



Music

Alexa, turn up the volume.
Alexa, play rock music.
Alexa, rewind 15 seconds.



Communication

Alexa, call Home.
Alexa, text “Hello” to John.
Alexa, call Hannah.



Miscellaneous

Alexa, what’s the weather?
Alexa, tell me a story.
Alexa, resume my audiobook.
Alexa, lock the front door.
Alexa, what’s on my to-do list?
Alexa, how does my day look?
Alexa, what movies are playing?
Alexa, what’s the news?

04 Charging Your Devices

Charging Ports

The Aivo Boost contains two charging ports—one USB-C and one USB-A. You can charge two devices at the same time.

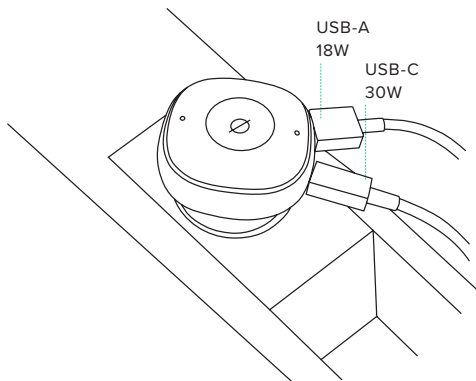

Index

Pour une expérience utilisateur optimale, veuillez suivre les instructions détaillées de ce manuel.

- 01 Guide de démarrage**
 - Besoins des utilisateurs
 - Spécifications de produits
 - Boutons de commande
 - Indicateurs LED
- 02 Mise en place du produit**
 - Mise sous tension
 - Mode de configuration
 - Ajouter un appareil
 - Alexa est prête
- 03 Utilisation d'Alexa**
 - Bienvenue à Alexa
 - Comment éveiller Alexa
- 04 Charger vos appareils**
 - Ports de recharge

01 Commencer

Bienvenue à l'Aivo Boost! Ce manuel vous guidera à travers les informations détaillées du produit, l'installation et le fonctionnement de l'appareil, l'utilisation d'Alexa, et bien plus encore!

Besoins des utilisateurs



Téléchargez l'application iOttie Connect dans l'Apple App Store ou dans le Google Play Store de votre smartphone.



Téléchargez l'application Amazon Alexa dans l'Apple App Store ou dans le Google Play Store de votre smartphone.



*Assurez-vous de disposer d'une connexion de données cellulaires et d'une source d'alimentation fiables pour utiliser Alexa.

Spécifications de produits

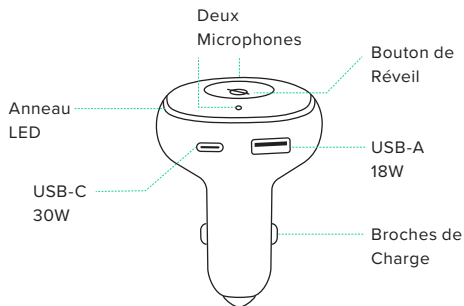

Article	Spécifications
Entrée totale	12–24V
Sortie USB-C	Jusqu'à 30W 5V/3A, 9V/2A, 12V/1.5A - PD3.0/QC4.0+
Sortie USB-A	Jusqu'à 18W 3.6-6.5V/3A, 6.5-9V/2A, 9-12V/1.5A - QC3.0
Sortie totale	48W
Profondeur	2.93"
Largeur	2"
Hauteur	2"
Poids	1.6oz

Boutons de commande

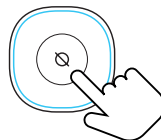

Appuyez sur:
réveillez Alexa

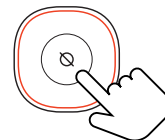

Appui long (3 sec):
désactiver/activer le son

Indicateur LED Alexa

- Mise sous tension
- Recherche de connexion Bluetooth
- Appareil introuvable
- Appareil connecté
- Mot de réveil activé
- En pensant
- Appareil non connecté
- En sourdine
- Aucune interaction en cours

02 Mise en place du produit

Mise sous tension

Branchez l'Aivo Boost dans la prise d'alimentation 12V de votre véhicule.

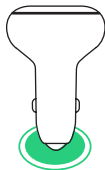

Mode de configuration

Démarrez le moteur et le mode paramétrage commencera automatiquement.

L'anneau LED clignote en orange lorsque vous êtes redirigé.



Ajouter un appareil

Dans l'application Alexa, accédez à Ajouter un appareil > Accessoire automatique, puis sélectionnez parmi les appareils disponibles : iOttie Aivo Boost (####) et jumelez l'appareil. Autorisez l'accès à l'emplacement et assurez-vous que le Bluetooth est.



Alexa est prête

L'anneau DEL clignote 3 fois en bleu lorsque la configuration de l'application Alexa est terminée. Vous pouvez maintenant utiliser l'application Alexa avec Aivo Boost.

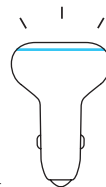

*L'appareil se connecte désormais automatiquement lorsqu'il est allumé et que votre smartphone est à portée de main.

*Pour dissocier l'appareil, maintenez le bouton pour évoquer Alexa pendant 5 secondes jusqu'à ce qu'il clignote en orange et sélectionnez « Oublier l'appareil » dans les paramètres Bluetooth du téléphone.



Mise à jour du firmware iOttie Connect App

Pour une expérience utilisateur optimale, assurez-vous que le firmware le plus récent est installé à partir de l'application iOttie Connect. Suivez les instructions de mise à jour du firmware dans l'application. Le firmware obsolète ne fonctionnera pas correctement.

03 Utilisation d'Alexa

Bienvenue à Alexa

Avec Alexa, les utilisateurs peuvent demander leur chemin, écouter de la musique, passer des appels mains libres, contrôler des appareils domestiques intelligents, et bien plus encore. Il suffit de demander!

Pour une expérience optimale, veuillez suivre les instructions détaillées pour la configuration d'Alexa trouvées dans le manuel ou l'application iOttie Connect.

- Certaines compétences Alexa peuvent nécessiter un abonnement Amazon Prime.
- Assurez-vous que le Bluetooth de votre téléphone est activé et connecté au Bluetooth de votre voiture.
- Le Aivo Boost avec Alexa intégré utilise vos données lorsqu'il n'est pas connecté au wifi. Une connexion réseau claire est nécessaire pour qu'Alexa fonctionne, sinon il peut y avoir des retards ou des interruptions. iOttie n'est pas responsable de l'utilisation des données.
- Alexa diffuse à partir du Cloud. Veuillez noter que cela peut utiliser des données. Des frais de données peuvent s'appliquer.

- Alexa diffuse des médias en streaming au lieu de fichiers locaux. Veuillez noter que cela peut utiliser des données. iOttie n'est pas responsable de l'utilisation des données
- Pour la messagerie vocale et les appels, veuillez autoriser les paramètres d'autorisations en allant à: Contacts > Profil et paramètres > Autorisation.

Comment éveiller Alexa

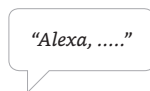

OR



Un mot de réveil peut être utilisé pour demander quoi que ce soit à Alexa. Le mot de réveil est tout simplement « Alexa ».

Le bouton pour évoquer Alexa peut également être utilisé à la place du mot de réveil.

- ! Il n'y aura aucun repère visuel sur votre smartphone qui annonce la connexion sauf que la couleur de la lumière LED d'Aivo Boost doit être bleue.
- ! L'application Alexa doit être exécutée en arrière-plan de votre téléphone pour que l'appareil fonctionne. Votre téléphone lancera automatiquement l'application Alexa en arrière-plan lors de la connexion.

04 Charger vos appareils

Ports de recharge

L'Aivo Boost possède deux ports de charge—un USB-C et un USB-A. Vous pouvez charger deux appareils en même temps.

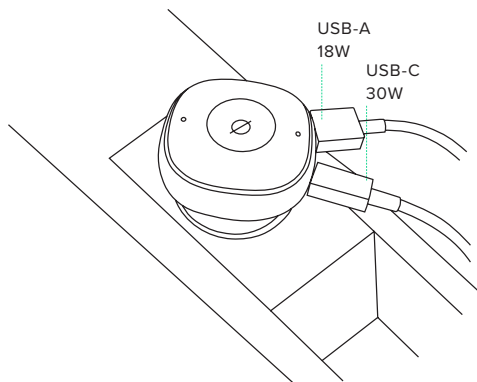

Indice

Segui questi passaggi nell'ordine seguente per impostare correttamente il tuo dispositivo.

01 Come iniziare

- Requisiti dell'utente
- Caratteristiche del prodotto
- Controlli dei pulsanti
- Indicatori LED

02 Installazione del prodotto

- Accensione
- Modalità di configurazione
- Aggiungi dispositivo
- Alexa è pronta

03 Come usare Alexa

- Benvenuto su Alexa
- Come svegliare Alexa

04 Caricamento dei dispositivi

- Porte di ricarica

01 Come iniziare

Benvenuti in Aivo Boost! Questo manuale spiegherà le informazioni dettagliate sul prodotto, l'installazione e il funzionamento del dispositivo, l'uso di Alexa e molto altro ancora!

Requisiti dell'utente



Scarica l'app iOttie Connect da Apple App Store o Google Play Store sul tuo smartphone.



Scarica l'app Amazon Alexa da Apple App Store o Google Play Store sul tuo smartphone.



*Assicurarsi di avere una connessione dati cellulare affidabile e una fonte di alimentazione per poter utilizzare Alexa.

Caratteristiche del prodotto

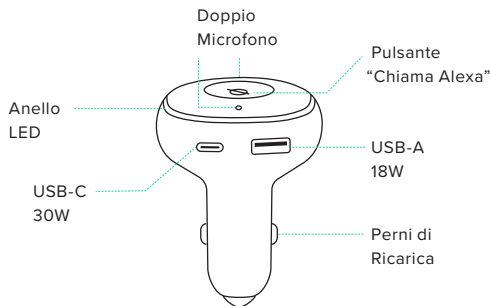

Elemento	Caratteristiche
Ingresso totale	12-24V
Uscita USB-C	Fino a 30W 5V/3A, 9V/2A, 12V/1.5A - PD3.0/QC4.0+
Uscita USB-A	Fino a 18W 3.6-6.5V/3A, 6.5-9V/2A, 9-12V/1.5A - QC3.0
Uscita totale	48W
Profondità	2.93"
Larghezza	2"
Altezza	2"
Peso	1.6oz

Controlli dei pulsanti

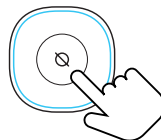

Premi:
Riattiva Alexa

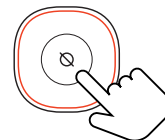

Tenere premuto (3 sec):
Disattivare/attivare l'audio

Indicatori LED

- Accensione
- Ricerca della connessione Bluetooth
- Dispositivo non trovato
- Dispositivo collegato
- Parola di attivazione azionata
- Pensiero
- Dispositivo non connesso
- Muto
- Nessuna interazione in corso

02 Installazione del prodotto

Accensione

Inserire Aivo Boost nella presa di corrente da 12V del veicolo e Avviare il motore.

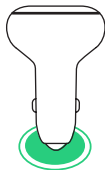

Modalità di configurazione

La modalità di configurazione inizierà automaticamente.

L'anello LED lampeggerà in arancione durante il reindirizzamento.

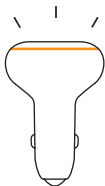

Aggiungi dispositivo

Nell'app Alexa, vai su Aggiungi dispositivo > Accessorio auto, quindi seleziona tra i dispositivi disponibili: iOttie Aivo Boost (####) e associa il dispositivo. Consenti l'accesso alla posizione e assicurati che il Bluetooth sia rilevabile e acceso.



Alexa è pronta

L'anello LED lampeggerà in blu 3 volte una volta che la configurazione di Alexa sarà completata. Alexa è pronta per essere utilizzata con Aivo Boost.

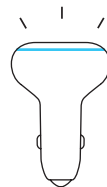

**Il dispositivo ora si conatterà automaticamente quando è acceso e il tuo smartphone è a portata di mano.*

**Per disabbinare il dispositivo, tieni premuto il pulsante "Chiama Alexa" per 5 secondi finché non lampeggia in arancione e seleziona "Dimentica dispositivo" dalle impostazioni Bluetooth del telefono.*



Aggiornamento del firmware del dispositivo tramite l'app iOttie Connect

Per un'esperienza utente ottimale, assicurati di avere il firmware del dispositivo aggiornato scaricarlo tramite l'app iOttie Connect. Segui le istruzioni nell'app per aggiornare il firmware del dispositivo.

03 Come usare Alexa

Benvenuto su Alexa

Con Alexa, gli utenti possono chiedere indicazioni, riprodurre musica, effettuare chiamate in vivavoce, gestire i dispositivi domestici intelligenti e molto altro.

Per un'esperienza ottimale, segui le istruzioni dettagliate nel manuale o nell'app iOttie Connect per la configurazione di Alexa.

- Alcune abilità di Alexa potrebbero richiedere un'iscrizione ad Amazon Prime.
- Assicurati che il Bluetooth del tuo telefono sia acceso e collegato al Bluetooth della tua tua auto.
- Aivo Boost con Alexa integrata utilizza i dati del tuo cellulare quando non è collegato al Wi-Fi. È necessaria una connessione di rete affidabile per far funzionare Alexa, altrimenti ci possono essere ritardi o interruzioni. iOttie non è responsabile per l'utilizzo dei dati.
- Alexa trasmette dal cloud e ciò può richiedere l'utilizzo dei dati che può comportare dei costi aggiuntivi.

- Alexa trasmette media invece di file locali e ciò può richiedere l'utilizzo dei dati. iOttie non è responsabile per l'utilizzo dei dati.
- Per la messaggistica vocale, si prega di consentire le impostazioni di autorizzazione andando su Contatti > Profilo e impostazioni > Autorizzazione.

Come svegliare Alexa

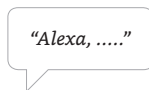

OR



La parola di attivazione può essere usata per chiedere ad Alexa qualsiasi cosa. La parola d'ordine è semplicemente "Alexa".

Il pulsante "Chiama Alexa" può essere utilizzato anche al posto della parola sveglia.

- ! Non ci sarà nessun segnale visivo sul tuo smartphone che annuncia la connessione, solo la luce LED blu di Aivo Boost.
- ! L'app Alexa deve essere in esecuzione in background sul tuo telefono affinché il dispositivo funzioni. L'app si riconnetterà automaticamente una volta aperta.

04 Caricamento dei dispositivi

Porte di ricarica

Aivo Boost contiene due porte di ricarica - una USB-C e una USB-A. È possibile caricare due dispositivi allo stesso tempo.

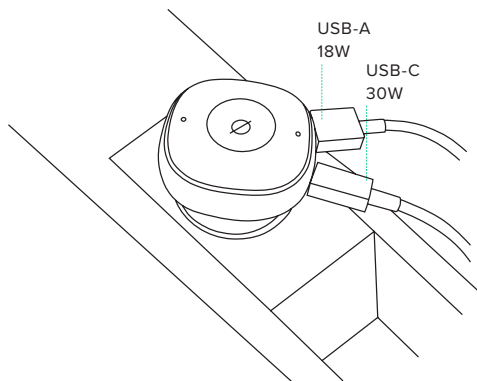

Index

Bitte befolgen Sie die ausführlichen Anweisungen in diesem Handbuch, um eine optimale Benutzererfahrung zu erhalten.

01 Erste Schritte

- Benutzeranforderungen
- Produktspezifikationen
- Steuerungstasten
- LED-Anzeigen

02 Einrichtung des Produkts

- Einschalten
- Konfigurations-Modus
- Gerät hinzufügen
- Alexa ist bereit

03 Alexa verwenden

- Willkommen bei Alexa
- So aktivieren Sie Alexa

04 Laden Ihrer Geräte

- Ladeanschlüsse

01 Erste Schritte

Willkommen bei Aivo Boost! Dieses Handbuch zeigt Ihnen alle Details zum Produkt, zur Installation und Bedienung des Geräts, zur Verwendung von Alexa und vieles mehr!

Benutzeranforderungen



Laden Sie die iOttie Connect-App aus dem Apple App Store oder dem GooglePlay Store auf Ihr Smartphone herunter.



Laden Sie die Amazon Alexa App aus dem Apple App Store oder dem GooglePlay Store auf Ihr Smartphone herunter.



*Stellen Sie sicher, dass Sie über eine zuverlässige Mobilfunk-Datenverbindung und Stromquelle verfügen, um Alexa verwenden zu können.

Produktspezifikationen

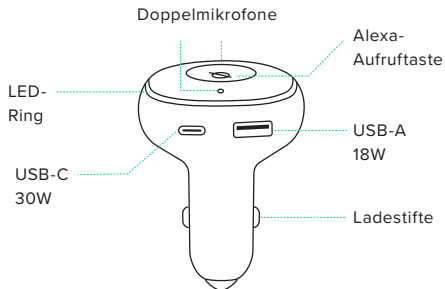

Artikel	Spezifikationen
Eingang	12–24V
Ausgabe USB-C	Bis zu 30W 5V/3A, 9V/2A, 12V/1.5A - PD3.0/QC4.0+
Ausgabe USB-A	Bis zu 18W 3.6-6.5V/3A, 6.5-9V/2A, 9-12V/1.5A - QC3.0
Gesamtleistung	48W
Tiefe	2.93"
Breite	2"
Höhe	2"
Gewicht	1.6oz

Steuerungstasten

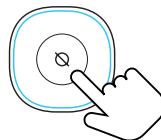

Drücken Sie:
Alexa wecken

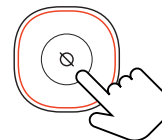

Gedrückt halten (3 Sek):
Stumm/Stumm schalten

LED-Anzeigen

- Einschalten
- Suche nach Bluetooth-Verbindung
- Gerät nicht gefunden
- Gerät ist angeschlossen
- Weckwort aktiviert
- Denken
- Gerät nicht angeschlossen
- Stumm geschaltet
- Keine Interaktion im Gange

02 Einrichtung des Produkts

Einschalten

Schließen Sie den Aivo Boost an die 12V Steckdose Ihres Fahrzeugs an.

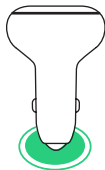

Konfigurations-Modus

Konfigurations-Modus verbindet sich automatisch.

Der LED-Ring blinkt orange auf, während Sie weitergeleitet werden.



Gerät hinzufügen

Navigieren Sie in der AlexaApp zu Add Device > Auto Accessory (Gerät hinzufügen > Autozubehör) und wählen Sie dann aus den verfügbaren Geräten: iOttie Aivo Boost (####) und koppeln Sie das Gerät. Lassen Sie den Zugriff auf den Standort zu und stellen Sie sicher, dass Bluetooth erkennbar und eingeschaltet ist.



Alexa ist bereit

Sobald das Gerät gekoppelt und angeschlossen ist, blinkt der LED-Ring dreimal blau, bevor er sich ausschaltet. Alexa ist nun einsatzbereit.

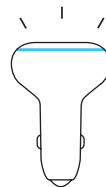

*Das Gerät verbindet sich nun automatisch, wenn es eingeschaltet ist und sich Ihr Mobiltelefon in der Nähe befindet.

*Um das Gerät zu entkoppeln, halten Sie die Alexa-Aufruftaste 5 Sekunden lang gedrückt, bis sie orangefarben blinkt. Wählen Sie dann "Gerät vergessen" aus den Bluetooth-Einstellungen des Mobiltelefons.



Firmware aktualisieren über die iOttie Connect-App

Für ein optimales Benutzererlebnis vergewissern Sie sich, dass Sie die aktuellste Firmware über die iOttie Connect-App installiert haben. Folgen Sie den Anweisungen zum Aktualisieren der Firmware in der App. Veraltete Firmware wird nicht ordnungsgemäß funktionieren.

03 Alexa verwenden

Willkommen bei Alexa

Mit Alexa können Sie nach dem Weg fragen, Musik abspielen, Anrufe tätigen, Hörbücher hören, Nachrichten hören, das Wetter überprüfen, Smart-Home-Geräte steuern und vieles mehr - und das alles, während Sie die Hände am Lenkrad und die Augen offen halten die Straße.

Befolgen Sie für eine optimale Erfahrung die detaillierten Anweisungen zur Einrichtung von Alexa im Handbuch oder in der iOttie Connect-App.

- Für einige Alexa Skills ist möglicherweise eine Amazon Prime-Mitgliedschaft erforderlich.
- Stellen Sie sicher, dass das Bluetooth Ihres Telefons aktiviert und mit dem Bluetooth Ihres Autos verbunden ist.
- Der Aivo Boost mit integrierter Alexa verwendet Ihre Mobilfunkdaten, wenn keine Verbindung zu WLAN besteht. Damit Alexa ordnungsgemäß funktioniert, ist eine eindeutige Netzwerkverbindung erforderlich. Andernfalls kann es zu Verzögerungen oder Unterbrechungen kommen. iOttie haftet nicht für die Datennutzung.
- Alexa strömt aus der Wolke. Bitte beachten Sie, dass hierfür möglicherweise Daten verwendet werden. Es können Datengebühren anfallen.

- Alexa überträgt Medien anstelle lokaler Dateien. Bitte beachten Sie, dass hierfür möglicherweise Daten verwendet werden. iOttie haftet nicht für die Datennutzung.
- Für Sprachnachrichten erlauben Sie bitte die Berechtigungseinstellungen, indem Sie zu Kontakte > Profil und Einstellungen > Berechtigung gehen.

So aktivieren Sie Alexa



OR



Ein Weckwort kann verwendet werden, um Alexa etwas zu fragen. Das Weckwort ist einfach "Alexa".

Tippen Sie auf die Wecktaste, anstatt den Weckbefehl zu verwenden.

- ! Auf Ihrem Smartphone wird kein visueller Hinweis angezeigt, der die Verbindung ankündigt, außer dass die Farbe des LED-Lichts von Aivo Boost blau sein sollte.
- ! Die Alexa App muss im Hintergrund Ihres Telefons ausgeführt werden, damit das Gerät funktioniert. Sobald die Verbindung hergestellt ist, startet Ihr Telefon die Alexa-App automatisch im Hintergrund.

04 Laden Ihrer Geräte

Ladeanschlüsse

Der Aivo Boost hat zwei Ladeanschlüsse—einen USB-C und einen USB-A-Anschluss. Sie können damit zwei Geräte gleichzeitig laden.

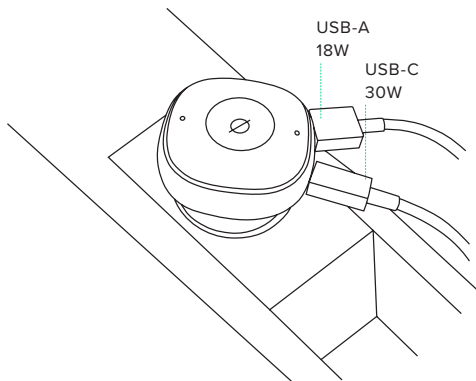

Indice

Para una experiencia de usuario óptima, siga las instrucciones detalladas de este manual.

01 Primeros pasos

- Requisitos del usuario
- Especificaciones del producto
- Controles mediante botones
- Indicadores LED

02 Configuración del producto

- Encendido
- Modo de configuración
- Añadir dispositivo
- Alexa está lista

03 Usar Alexa

- Bienvenido a Alexa
- Cómo despertar a Alexa

04 Carga de los dispositivos

- Puertos de carga

01 Primeros pasos

¡Bienvenido a Aivo Boost! Este manual le mostrará información detallada sobre el producto, la instalación y el funcionamiento del dispositivo, el uso de Alexa y mucho más.

Requisitos del usuario



Descargue la aplicación iOttie Connect en la Apple App Store o Google Play Store en su teléfono.



Descargue la aplicación Amazon Alexa en la Apple App Store o Google Play Store en su teléfono.



***Asegúrese de tener una conexión de datos móviles y una fuente de alimentación fiables para poder utilizar Alexa.**

Especificaciones del producto

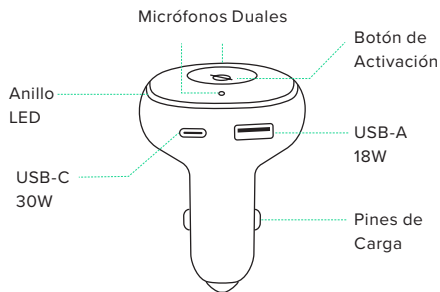

Elemento	Especificaciones
Entrada total	12–24V
Salida USB-C	Hasta 30W 5V/3A, 9V/2A, 12V/1.5A - PD3.0/QC4.0+
Salida USB-A	Hasta 18W 3.6–6.5V/3A, 6.5–9V/2A, 9–12V/1.5A - QC3.0
Salida total	48W
Profundidad	2.93"
Ancho	2"
Altura	2"
Peso	1.6oz

Controles mediante botones

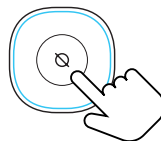

Presione:
Despertar a Alexa

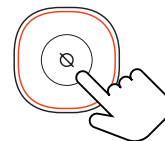

Presione y Mantenga (3 seg):
Silenciar/Quitar Silencio

Indicadores LED

- Encendiendo
- Buscando conexión Bluetooth
- Dispositivo no encontrado
- El dispositivo está conectado
- Palabra Wake activada
- Pensando
- Dispositivo no conectado
- Silenciado
- Ninguna interacción actual

02 Configuración del producto

Encendido

Enchufe el Aivo Boost en la toma de corriente de 12V de su vehículo, luego encienda el motor.

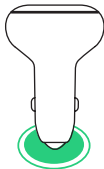

Modo de configuración

Modo de configuración se comenzará automáticamente.

El anillo LED parpadeará en color naranja mientras se le redirige.

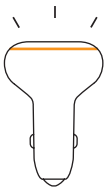

Añadir dispositivo

En la aplicación Alexa, vaya a Agregar dispositivo > Accesorio de auto, luego seleccione de los dispositivos disponibles: iOttie Aivo Boost (####) y empareje el dispositivo. Permita el acceso a la ubicación y asegúrese de que Bluetooth esté encendido y sea detectable.



Alexa está lista

Una vez que el dispositivo está emparejado y conectado, el anillo LED parpadea en azul tres veces antes de apagarse. Alexa ahora está lista para usarse.

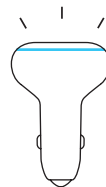

*El dispositivo ahora se conectará automáticamente cuando se encienda y su teléfono inteligente esté cerca.

*Para desvincular el dispositivo, mantenga presionado el botón Invocar Alexa durante 5 segundos hasta que parpadee en naranja, y seleccione "Olvidar dispositivo" en la configuración de Bluetooth del teléfono.



Actualización del firmware del dispositivo a través de la aplicación iOttie Connect

Para una experiencia de usuario óptima, asegúrese de tener instalado el firmware más actualizado del dispositivo desde la aplicación iOttie Connect. Siga las instrucciones para actualizar el firmware del dispositivo en la aplicación.

03 Usar Alexa

Bienvenido a Alexa

Con Alexa, puede pedir indicaciones para llegar a un sitio, reproducir música, hacer llamadas, escuchar audiolibros, escuchar las noticias, consultar el clima, controlar dispositivos domésticos inteligentes y mucho más, todo mientras mantiene las manos en el volante y la vista en el camino.

Para una experiencia óptima, siga las instrucciones para la configuración de Alexa indicadas en el manual o en la aplicación iOttie Connect.

- Algunas skills de Alexa pueden requerir una membresía de Amazon Prime.
- Asegúrese de que el Bluetooth de su teléfono esté encendido y conectado al Bluetooth de su automóvil.
- El Aivo Boost con Alexa integrada usa sus datos celulares cuando no está conectado a WiFi. Se requiere una conexión de red fuerte para que Alexa funcione correctamente; de lo contrario, puede haber retrasos o interrupciones. iOttie no se hace responsable del uso de datos celulares.
- Alexa transmite desde la nube. Tenga en cuenta que esto puede usar datos celulares. Se pueden aplicar cargos por datos celulares.

- Alexa transmite medios digitales en lugar de archivos locales. Tenga en cuenta que esto puede usar datos celulares. iOttie no se hace responsable del uso de tales datos.
- Para mensajería de voz, permita la configuración de permisos en Contactos > Perfil y configuración > Permiso.

Cómo despertar a Alexa

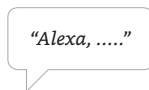

OR



Se puede usar una palabra Wake para preguntarle cualquier cosa a Alexa. La palabra Wake es "Alexa".

Toque el botón activación en lugar de usar la palabra para despertar.

- ! No habrá ninguna señal visual en su teléfono inteligente que confirme la conexión, excepto que el color de la luz LED de Aivo Boost debe ser azul.
- ! La aplicación Alexa debe estar ejecutándose en segundo plano en su teléfono para que el dispositivo funcione. Su teléfono iniciará automáticamente la aplicación Alexa en segundo plano al conectarse.

04 Carga de los dispositivos

Puertos de carga

El Aivo Boost tiene dos puertos de carga: uno USB-C y otro USB-A. Puedes cargar dos dispositivos al mismo tiempo.

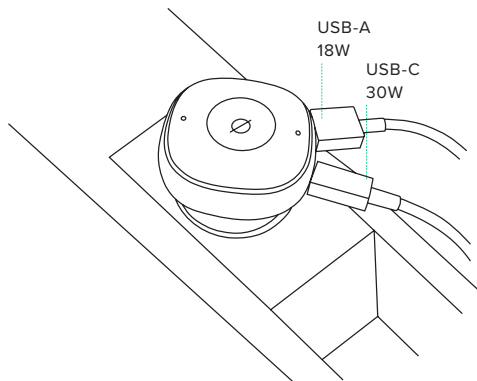

目次

最適なユーザー体験のため、このマニュアルの詳細な指示に従ってください。

01 使用前の準備

ユーザーへのお願い
製品の仕様書
ボタンコントロール
LEDインジケーター

02 製品セットアップ

電源オン
セットアップモード
デバイスの追加
Alexaの準備ができました

03 Alexaを使用する

Alexaによるこ
Alexaの起動方法

04 デバイスを充電する

充電ポート

01 使用前の準備

Aivo Boostようこそ! このマニュアルは、製品の
詳細情報、デバイスのインストールと作動、Alexaの
使い方などをご紹介します!

ユーザーへのお願い



iOttieコネクートをアップルの App StoreまたはGoogle Playストアからお手持ちのスマホにダウンロードしてください。



アマゾンAlexaアプリをアップルの App StoreまたはGoogle Playストアからお手持ちのスマホにダウンロードしてください。



*信頼できるWiFiまたはモバイル通信を使用し、電源に接続していることを確認してください。



製品の仕様書

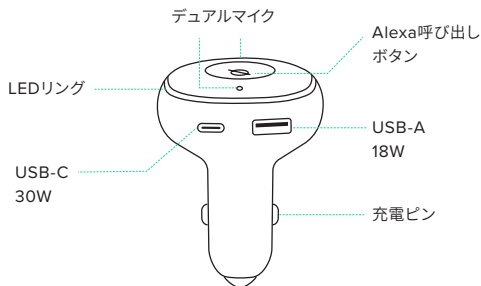

アイテム	仕様
電源	12 - 24V
USB-C出力	最大 30W 5V/3A, 9V/2A, 12V/1.5A - PD3.0/QC4.0+
USB-A出力	最大18W 3.6-6.5V/3A, 6.5-9V/2A, 9-12V/1.5A - QC3.0
総出力	48W
奥行	2.93インチ
幅	2インチ
高さ	2インチ
重量	1.6オンス

ボタンコントロール

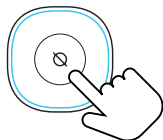









プレス:
ウェイクアレクサ



押し続ける (3秒):
ミュート/ミュート解除

LEDインジケーター

-  電源オン
-  デバイスを検索中
-  デバイスが見つかりません
-  デバイ스에接続済み
-  起動メッセージ
-  考え中
-  デバイ스가未接続
-  ミュート
-  進行中のやり取りはありません

02 製品のセットアップ

電源オン

家用車の12V電源ソケットに Aivo Boostをつなぎます。エンジンをかけます。

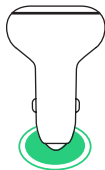

セットアップモード

自動的にセットアップモードが始まります。

電源を切り替える間、LEDリングがオレンジに光ります。



デバイスの追加

Alexaアプリで、デバイスの追加 > 車のアクセサリーを開き、利用可能なデバイスiOttie Aivoコネクタ(####)を選択し、デバイスをペアリングします。位置情報へのアクセスを許可し、Bluetoothが検知可能でオンになっていることを確認します。



Alexa の準備ができました

デバイスのペアリングと接続が完了したら、オンになる前にLEDリングが3回点滅します。Alexaを使用する準備ができました。

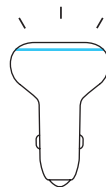

*これでデバイスの電源がオンになっていて、スマホが近くにある時は、自動的に接続されるようになりました。

*デバイスのペアリングを解除するには、オレンジに点滅するまで、Alexa 呼び出しボタンを5秒間押し、スマホの Bluetooth設定画面で「デバイスを解除する」を選んでください。



iOttie コネクトアプリ経由でデバイスのファームウェアを更新する

最適なユーザ体験のため、iOttieコネクトアプリからデバイスの最新のファームウェアをインストールしているか確認してください。アプリ内の、デバイスのファームウェアを更新する方法に関する指示に従ってください。

03 Alexa を使用する

Alexaによるこそ

Alexaがあれば、ハンドルを握り、道路に目を向けながら、道案内を尋ねたり、音楽をかけたり、電話したり、オーディオブックやニュースを聞いたり、天気予報をチェックしたり、スマートホーム機器を操作したり、他にも様々なことができます。

最適な体験のため、取扱説明書やiOttieコネクタアプリにあるAlexaの設定に関する詳細な指示に従ってください。

- Alexa技術にはアマゾンプライム会員でないと利用不可なものがあります。
- スマホのBluetoothがオンになっており、車のBluetoothに接続されているか確認してください。
- Alexa内蔵のAivo Boostは、WiFi未接続時にデータ通信を使用します。Alexaの適切な作動には、強力なネットワーク接続が必要で、さもないと遅延や障害が生じる場合があります。iOttieはデータ通信量に対する責任を負いません。
- Alexaはデータ通信を利用してクラウドからストリームする場合があります。データ通信料金が発生するかもしれません。

- Alexaはローカルファイルではなく、データ通信を利用してメディアを流す場合があるのでご注意ください。iOttieはデータ通信量の責任を負いません。
- ボイスメッセージを利用するには、連絡先>プロフィールと設定>許可 から設定を行ってください。

Alexaの起動方法



OR



Alexaに何を聞くにしても、ウェイクワードを使います。ウェイクワードはシンプルに“Alexa”です。

起動の言葉をかける代わりに、Wakeボタンをタップします。

- ❗ お手持ちのスマホには接続を知らせる表示はなく、AivoコネクタのLEDライトがブルーになるだけです。
- ❗ デバイスの稼働には、お手持ちのスマホのバックグラウンドでAlexaアプリが起動していなければなりません。携帯電話と接続しておくと、バックグラウンドで自動的にAlexaアプリが起動されます。

04 デバイスを充電する

充電ポート

Aivo Boostには充電ポートが二つあります – 一つはUSB-Cでもう一つはUSB-Aです。同時に二つのデバイスを充電できます。

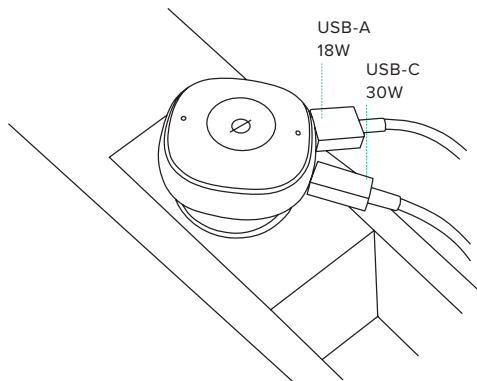

Operation Warnings

This device complies with part 15 of the FCC rules. Operation is subject to the following two conditions: (1) this device may not cause harmful interference, and (2) this device must accept any interference received, including interference that may cause undesired operation.

NOTE: The manufacturer is not responsible for any radio or TV interference caused by unauthorized modifications to this equipment. Such modifications could void the user's authority to operate the equipment.

NOTE: This equipment has been tested and found to comply with the limits for a Class B digital device, pursuant to part 15 of the FCC Rules. These limits are designed to provide reasonable protection against harmful interference in a residential installation. This equipment generates uses and can radiate radio frequency energy and, if not installed and used in accordance with the instructions, may cause harmful interference to radio communications. However, there is no guarantee that interference will not occur in a particular installation. If this equipment does cause harmful interference to radio or television reception, which can be determined by turning the equipment off and on, the user is encouraged to try to correct the interference by one or more of the following measures:

- Reorient or relocate the receiving antenna.
- Increase the separation between the equipment and receiver.
- Connect the equipment into an outlet on a circuit different from that to which the receiver is connected.

- Consult the dealer or an experienced radio/TV technician for help.
- This device and its antenna(s) must not be co-located or operating in conjunction with any other antenna or transmitter.

This equipment complies with FCC radiation exposure limits set forth for an uncontrolled environment. This equipment should be installed and operated with minimum distance of 20 cm between the radiator and your body. This transmitter must not be co-located or operating in conjunction with any other antenna or transmitter.

Operating temperature: -10-55°C

Operating frequency range: 2402-2480MHz

Rated Power: For Classic: 9.1dBm, BLE: 8.1dBm

Declaration of Conformity: Hereby, iOttie, Inc. declares that the radio equipment type Aivo Boost of **CHCRIO201** is in compliance with Directive 2014/53/EU.

The full text of the EU declaration of conformity is available at the following internet address: www.iottie.com

This device may be used in each EU member state.

Important Safety Information

This manual contains important safety and operating instructions for the Aivo Boost Alexa Built-in Dual Car Charger (SKU# CHCRIO201).

Please read all instructions and safety information before using this product. If damage occurs as a result of failure to follow the instructions, the warranty will be voided.



- Do not expose to rain, moisture, or snow.
- Using an attachment made or sold by anyone other than the manufacturer is not recommended. Doing so may result in an increased risk of fire, electric shock, or injury.
- Do not operate this dual port car charger if it has received a sharp blow, been dropped, or otherwise damaged in any way; take it to a qualified service person.
- Do not disassemble this dual port car charger; take it to a qualified service person when service or repair is required. Incorrect reassembly may result in electric shock or fire.
- To reduce the risk of electric shock, unplug this car charger before attempting any maintenance or cleaning. Turning off the vehicle controls will not reduce this risk.
- Avoid extended exposure to direct sunlight, which may damage the device.
- Exposing this product to open flames may cause it to explode.
- Do not expose this product to strong magnetic fields.
- Use a dry, soft, lint-free cloth to clean. Do not use any corrosive cleaner or oil to clean.
- Always obey traffic laws and pay attention to the road. Do not attempt to use this device while driving.



The Aivo Boost is backed by a 2 year warranty.

iottie